

## SMG 10/15/25

# High performance machines for plastic strapping



SMG 10/15



SMG 25

### Customer benefits

#### Characteristics

Up to 70 cycles per minute

Touch Panel

Simple technology, few moving parts

Constant strap tension

Ergonomically positioned dispenser

Machine, strap and after-sales service as a total package

#### Customer benefits

- Fast strapping
- Strap tension easily adjustable
- No overhanging operating functions
- All operating functions using foot pedal
- Reliable, also in continuous operation
- Easily accessible (without tools)
- For small to large packages
- For soft and hard products
- Simple and rapid coil change
- Strapex – your solution provider

## Specifications

Machines	SMG 10	SMG 15	SMG 25
	5/6 mm	9/12 mm	9/12 mm
<b>Standard equipment</b>			
Adjustable working height			
Four castors, with two braked			
Closed strap arch system			
Heat seal			
Automatic strap threading device			
Automatic strap end ejection			
Foot pedal			
Touch Panel with additional strap tension "Soft"			
Automatic strap loop ejection for cycles without product			
Cycle counter			
Electrical supply cable, 5 m			
Dispenser: position	Integrated	Integrated	Side mounted
<b>Technical data</b>			
Max. cycles	70/min.	65/min.	60/min.
Arch dimensions (width x height)			
– 500 x 400 mm	5/6 mm		
– 650 x 500 mm	5/6 mm	9/12 mm	
– 850 x 650 mm			9/12 mm
– 850 x 850 mm			9/12 mm
– 1250 x 500 mm			9/12 mm
– 1250 x 850 mm			9/12 mm
– 1550 x 500 mm			9/12 mm
Working height	820–930 mm	820–930 mm	820–930 mm
Electrical supply	230 V, 50 Hz	230 V, 50 Hz	230 V, 50 Hz
Strap tension, up to	300 N	450 N	450 N
Weight	170 kg	170 kg	190 kg
Room temperature	10–40°C	10–40°C	10–40°C
Relative humidity of air	10–65%	10–65%	10–65%
<b>Plastic strap (PP)</b> Width	5 mm	372.605.585	
	9 mm		371.609.555
	12 mm		371.612.540
Strap coil, inside/outside Ø	200/430 mm	200/430 mm	200/430 mm
<b>Packages</b> Min. width / Max. weight	100 mm / 35 kg	100 mm / 35 kg	100 mm / 35 kg
Second foot pedal	•	•	•
Foot switch with protection cover			•
Bundle stops	•	•	•
Cycle start triggered by photocell (on table)	•	•	•
Hold down device			•
Roller table		•	•
Signal lamp			•
Working height 670–830 mm			•
Interface			•

## Options

SMG 10/15

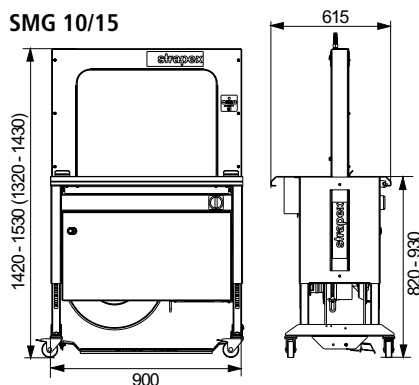

SMG 25

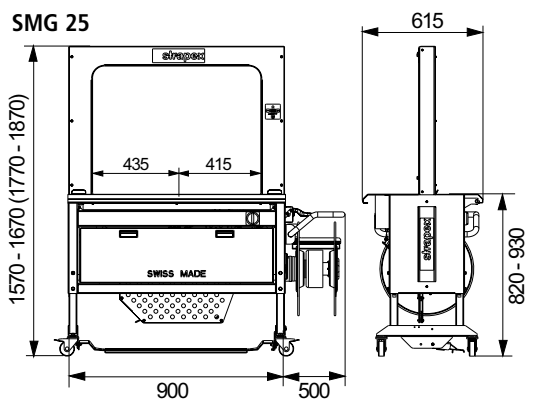

## Highlights



### Exceptionally easy operation

Strap tension adjustable with press button (+/-)

Strap tension "Soft" for delicate products



### Easy fault clearance without tools



### Lightweight strap for cost effective strapping

New technology allows use of thin or narrow 5 mm strap as alternative to 9/12 mm



### Minimum maintenance requirement without tools



### Robust, compact design

Easily accessible (without tools), simple and rapid coil change

## Options

### CT Version (Cold and Tropic Environment) SMG 10/15/25

Room temperature:

5–40°C

Relative humidity of air:

10–85%

- Rust-free feet and guide rolls
- Rust-free table
- Basic frame with special colour treatment



### Cycle start triggered by photocell

for single, double or multiple strapping



### Second foot pedal

for operation on both sides



### Hold down device

for compressing packages and loose bundles



### Foot switch with protection cover



### Roller table

for easy handling of heavy parcels



### Bundle stops

for precise positioning of loose packages



### Signal lamp

Triple or quadruple



### Interface

for integration into existing production lines

# Strapex worldwide



- Own development and production
  - Hand tools
  - Machines/Installations
  - Strap
- Own sales and service organisations
- Independent sales and service partners worldwide

## Australia

IWD Strapping Sales Pty Ltd.  
 AU-Melbourne VIC 3001  
 Phone +1 800 779 380  
[sales@iwdstrapping.com.au](mailto:sales@iwdstrapping.com.au)

## Austria

Strapex GmbH  
 AT-3500 Krems  
 Phone +43 2732 73 501  
[sales@strapex.at](mailto:sales@strapex.at)

## Belgium

Strapex Sprl  
 BE-1400 Nivelles  
 Phone +32 67 34 69 10  
[sales@strapex.be](mailto:sales@strapex.be)

## Brasil

Syspack Ind. Com. de Sistemas  
 de Emb. Ind. Ltda  
 BR-Jundiai - São Paulo 13208-080  
 Phone +55 11 2709-6835  
[jnogueira@syspack.com.br](mailto:jnogueira@syspack.com.br)

## Denmark

ApS Strapex  
 DK-2740 Skovlunde  
 Phone +45 44 85 06 00  
[sales@strapex.dk](mailto:sales@strapex.dk)

## Finland

Strapex / Oy Josef Kihlberg Ab  
 FI-15230 Lahti  
 Phone +358 388 08 80  
[reception.oy@kihlberg.fi](mailto:reception.oy@kihlberg.fi)

## France

Strapex S.A.S.  
 FR-94204 Ivry-sur-Seine  
 Phone +33 1 49 87 01 60  
[sales@strapex.fr](mailto:sales@strapex.fr)

## Germany

Strapex GmbH  
 DE-71088 Holzgerlingen  
 Phone +49 7031 68 04 0  
[info@strapex.de](mailto:info@strapex.de)

## Holland

Strapex Nederland BV  
 NL-3542 DK Utrecht  
 Phone +31 30 248 03 11  
[sales@strapex.nl](mailto:sales@strapex.nl)

## India

Strapex India Limited  
 IN-Mumbai 400 059  
 Phone +91 22-6640 0204/0205  
[info@strapex.co.in](mailto:info@strapex.co.in)

## Italy

Strapex S.r.l.  
 IT-20013 Magenta (Milano)  
 Phone +39 02 97 00 751  
[sales@strapex.it](mailto:sales@strapex.it)

## Mexico

Flejes Misa  
 MEX-Apodaca, N.L. CP 66610  
 Phone +52 (81) 81 58 78 00  
[ventas@flejesmisa.com.mx](mailto:ventas@flejesmisa.com.mx)

## Norway

Strapex / Josef Kihlberg AS  
 NO-7448 Trondheim  
 Phone +47 7382 06 00  
[reception.as@kihlberg.no](mailto:reception.as@kihlberg.no)

## Poland

Transaco Group Sp. z o.o.  
 PL-58-200 Dzierzoniow  
 Phone +48 74 833 50 02  
[transaco@transaco.pl](mailto:transaco@transaco.pl)

## Portugal

Strapex Embalagem Lda  
 PT-2794-051 Carnaxide  
 Phone +351 21 416 47 80  
[sales@strapex.pt](mailto:sales@strapex.pt)

## Russia

Roxor Industry  
 RU-199178 St Petersburg  
 Phone +7 800 555 7850  
[info@roxor.ru](mailto:info@roxor.ru)

## Singapore

Sypsex Singapore Pte Ltd  
 SG-Singapore 637848  
 Phone +65 6863 9119  
[sypsex@singnet.com.sg](mailto:sypsex@singnet.com.sg)

## Spain

[www.strapex.es](http://www.strapex.es)

## Sweden

Strapex / Josef Kihlberg AB  
 SE-544 22 Hjo  
 Phone +46 503 328 00  
[reception@kihlberg.se](mailto:reception@kihlberg.se)

## Switzerland

Strapex GmbH  
 CH-5610 Wohlten  
 Phone +41 56 619 80 80  
[info@strapex.ch](mailto:info@strapex.ch)

## United Kingdom

Strapex  
 GB-Aldridge, Walsall, WS9 8UQ  
 Phone +44 1922 742 500  
[info@strapex.co.uk](mailto:info@strapex.co.uk)

## USA

Acme  
 USA-Elmhurst, IL 60126  
 Phone 630-589-5100  
[info@acme-ds.com](mailto:info@acme-ds.com)

## All other countries

Strapex Partners  
 c/o ORGAPACK GmbH  
 Packaging Technology  
 CH-8953 Dietikon (Switzerland)  
 Phone +41 44 745 50 50  
[partners@strapex.com](mailto:partners@strapex.com)

MEMBER OF  
 ORGAPACK STRAPEX GROUP